

MC221

Description

This manual describes the MC150 display series. The purpose of this device is to display linear or angular displacements on industrial machines and automation systems. The device can be connected to standard Push-Pull or Line Driver incremental encoders or magnetic sensors.



Chapters

- 1 Safety summary
- 2 Identification
- 3 Installation
- 4 Mounting recommendations
- 5 Electrical connections
- 6 Functions
- 7 Set up
- 8 RS232 interface
- 9 Dimensional drawing and cut-out

1 - Safety summary

For the electrical connections, we recommend to closely follow these electrical instructions. In particular, according to the 89/336/EEC norm on electromagnetic compatibility, following precautions must be taken:

- Measurement system (sensor) should be installed as close as possible to the display.
- Always use shielded and twisted cables if possible.
- Avoid running the sensor cable near high voltage power cables (e.g. drive cables).
- Install EMC filters on sensor power supply if needed.
- Avoid mounting sensor near capacitive or inductive noise sources and switching power supplies.
- static discharge can damage internal sensitive electronic components. Before handling and installing, discharge electrical charge from your body and tools which may come in touch with the device.



Connect according to the chapter 5: "Electrical connections".

2 - Identification

The device can be identified by the label's data (ordering code, serial number). This information is listed in the delivery document. For technical features of the product to make reference at the technical catalogue.

3 - Installation

Install the device according to the protection level provided. Protect the system against knocks, friction, solvents and respect the environmental characteristics of the product.

4 - Mounting recommendations

Push the display into the cut-out (approx. 92 x 92 mm²) without panel clips. Install panel clips on the display's housing and screw until fixed.

5 - Electrical connections

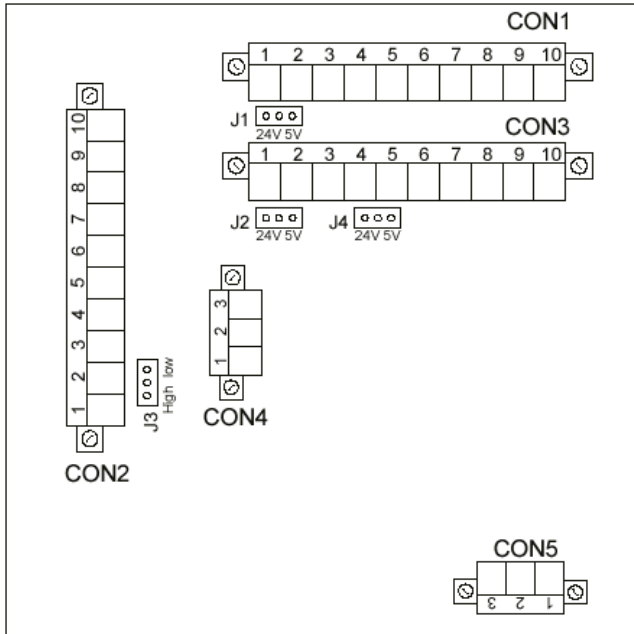

5.1 CON5 Connections (power supply) Power supply 24Vdc

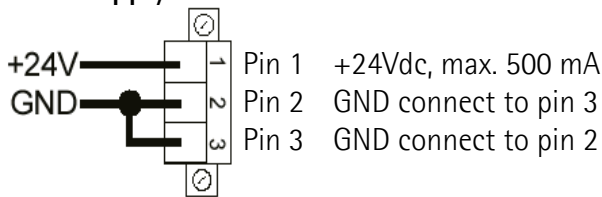

5.2 CON1 Connections: Axis 1 (PP, LD)

Pin	Function
1 *	GND
2 *	+24Vdc (J1 at left, power supply: 24Vdc) +5Vdc (J1 at right, power supply: 24Vdc)
3	A
4	/A (see parameter P22)
5	B
6	/B (see parameter P22)
7	0
8	/0 (see parameter P22)
9	P.E.
10	P.E.

*: sensor power supply

5.3 CON3 Connections: Axis 2 (PP, LD)

Pin	Function
1 *	GND
2 *	+24Vdc (J1 at left, power supply: 24Vdc) +5Vdc (J1 at right, power supply: 24Vdc)
3	A
4	/A (see parameter P22)
5	B
6	/B (see parameter P22)
7	0
8	/0 (see parameter P22)
9	P.E.
10	P.E.

*: sensor power supply

5.4 CON2 Connections (Inputs and Outputs)

Pin	Function
1	+24Vdc input power supply for output 2
2	Output 2 (PNP) *
3	+24Vdc input power supply for output 1
4	Output 1 (PNP) *
5	Input 4 - OFFSET/ Tx position with RS232
6	Input 3 - FREEZE/ STOP/ Abs.-incremental
7	Input 2 - SET
8	Input 1 - RESET
9	GND output for function inputs
10	+24Vdc output for function inputs

*: available only with "MC221-P1-..."

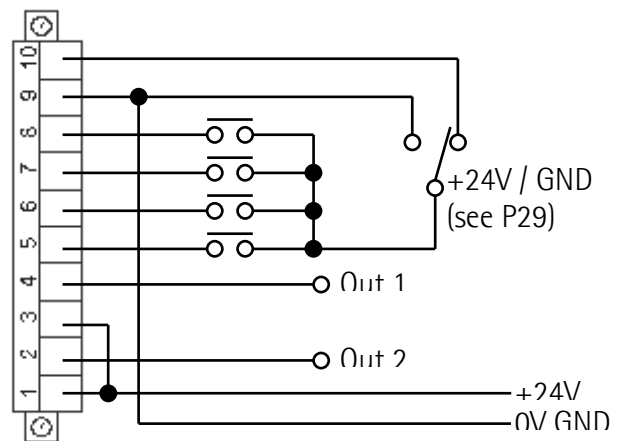

5.5 CON4 Connections (RS232)

Pin	Function
1	RxD
2	TxD
3	GND

5.6 J1 Jumper (encoder power supply)

Position	Function
Left	+24Vdc
Right	+5Vdc

5.7 J3 Jumper (input signal level)

Position	Function
Left	inputs connected to GND (CON2/Pin9)
Right	inputs connected to +24Vdc (CON2/Pin10)

6 - Setup

6.1 Key functions

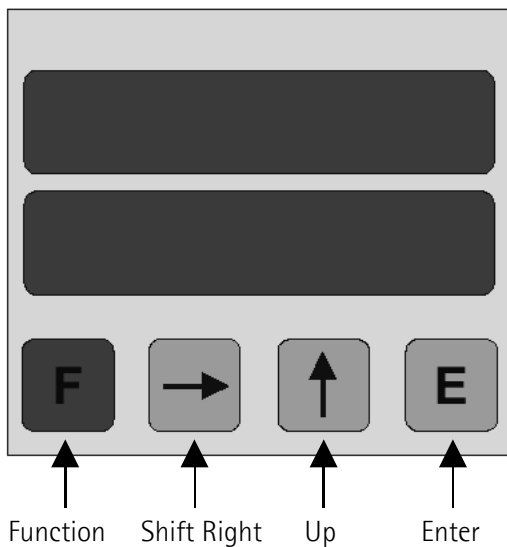

Key	Function
F	Function (save + exit setup)
➔	Shift Right (select parameter / digit)
⬆	Up (change value)
E	Enter (save + scroll menu)

6.2 Default parameter (factory settings)

Default parameter values are written in **BOLD** characters. The unit can be reset to default values by pushing F, ➔ and E key while switching on.

6.3 Direct functions

To set direct functions, such as reset, reset with datum value, tool correction (offset value), absolute/relative display mode and mm/Inch display mode, program **P06** parameter.

7 - Set up

7.1 Access to setup menus

Push **F** key to enter setup.

Push ➔ to select:

menu 1: **Cal** calibration value function level

menu 2: **All** general parameter level

menu 3: **Axis1** axis1 parameter level

menu 4: **Axis1** axis2 parameter level

Push **E** to scroll parameters

Push **F** to exit setup

Admissible value range for each parameter is listed as follows: [min. value, max. value]

7.2 Parameter setting

Menu 1: Cal

P00 Datum value / Preset [-99999, 999999]

In the calibration level you can calibrate both axes to a value. Each time this level is opened, the device proposes the value stored in Parameter P02, in levels Axis1 and Axis2. If the desired axis is selected by pressing **E** key, then the value can be set by holding the **E** key down for two seconds.

Menu 2: All

P00 Number of axes displayed [1, 2]

Contains the number of axes to display.

P01 Device ID

Contains the device MC2XX

P02 Software version

Current software version of the device.

P06 Function of the push buttons [0, 6]

The function of the ⬆ and the E button in operating mode can be selected.

0 = no functions

1 = **E** sets Axis 1 value to zero

F+E sets Axis 2 value to zero

2 = ⬆ set Axis 1 value to Datum/Preset

F+⬆ set Axis 2 value to Datum/Preset

3 = both functions 1 + 2

4 = ➔+⬆ activates Axis 1 offset

F+➔+⬆ activates Axis 2 offset

6 = both functions 2 + 4

8 = ➔ sets absolute/incremental mode

9 = both functions 1 + 8

- 10= both functions 2 + 8
- 11= functions 1 + 2 + 8
- 12= both functions 4 + 8
- 14= functions 2 + 4 + 8
- 16= E (hold key down for 2 sec.)
sets Inch/mm mode
- 18= both functions 2 +16
- ...

P07 Input 1: Reset function [0, 3]

Sets function of Reset input.

- 0 = static reset axis 1. Sets actual value to 0 until input is activated (high).
- 1 = dynamic reset axis 1. Edge triggered Reset input.
- 2 = static reset axis 2. Sets actual value to 0 until input is activated (high).
- 3 = dynamic reset axis 2. Edge triggered Reset input.

P08 Input2: SET function [0, 3]

Sets function of SET input.

- 0 = static SET axis 1. Sets display to Preset value until input is activated (high).
- 1 = dynamic SET axis 1. Edge triggered SET input.
- 2 = static SET axis 2. Sets display to Preset value until input is activated (high).
- 3 = dynamic SET axis 2. Edge triggered SET input.

P09 Input 3:

Freeze/Stop/Absolute-incr. function [0, 6]

Sets function of Freeze/Stop input.

- 0 = freeze axis 1. The display value for Axis 1 is frozen as long as the input is active.
- 1 = stop axis 1. Axis 1 stops counting as long as this input is active.
- 2 = Axis 1. Incremental/absolute using Input 3
- 4 = freeze axis 2. The display value for Axis 2 is frozen as long as the input is active.
- 5 = stop axis 2. Axis 2 stops counting as long as this input is active.
- 6 = Axis 2. Incremental/absolute using Input 3

P10 Input 4: Offset function [0, 1]

Here you assign an axis to Input 4

- 0 = Offset Axis 1 active.
- 1 = Offset Axis 2 active.

The offset function using the external input is only active however when the offset function from the front panel keys is disabled.

P29 Function input configuration [0, 15]

Chose from NO (Normally Open) or NC (Normally Closed), low active (connected with GND) or high active (connected with +24Vdc).

P29		CON3			
Con. with GND	Con. with +24Vdc	Pin 5	Pin 6	Pin 7	Pin 8
0	15	NO	NO	NO	NO
1	14	NC	NO	NO	NO
2	13	NO	NC	NO	NO
3	12	NC	NC	NO	NO
4	11	NO	NO	NC	NO
5	10	NC	NO	NC	NO
6	9	NO	NC	NC	NO
7	8	NC	NC	NC	NO
8	7	NO	NO	NO	NC
9	6	NC	NO	NO	NC
10	5	NO	NC	NO	NC
11	4	NC	NC	NO	NC
12	3	NO	NO	NC	NC
13	2	NC	NO	NC	NC
14	1	NO	NC	NC	NC
15	0	NC	NC	NC	NC

P30 Memory on power down [0, 1]

0 = actual value will be stored on power down

- 1 = after turning power off and on Display shows "Cal". Display has to be Datumed again before use.

P36 Count modes [0, 2]

- 0 = Standard 2-axis count mode. Both axes are counted independently of each other and displayed in the respective window.
- 1 = Differential counter. Count value = Count value of Axis 1 - Count value of Axis 2
The result is displayed in the upper window.
"diFF" appears in the lower window
- 2 = Sum counter. Count value = Count value of Axis 1 + Count value of Axis 2
The result is displayed in the upper window.
"SUMM" appears in the lower window

P42 Password Level 2, 3 and 4 [0, 999999]

Enter desired code number here to prevent operator from entering the "Parameter mode" (Level 2, 3 and 4).

Default value: 0

P44 Password Level 1 [0, 999999]

Enter desired code number here to prevent operator from entering the "Datum value mode" (Level 1).

Default value: **0**

Attention: Datum value can be set only after digiting the correct password.

To cancel password and restore default value see chapter "Default parameter" (6.2).

Setup for devices with RS232 serial interface (option I1)

P90 Display address [11, 99]

Enter here the serial address of the readout when using the serial interface option RS232. Don't use addresses 20, 30, 40,....., 90.

Default value: **11**

P91 Baud rate [0, 4]

The following baud rates are available.

0 = 2400

1 = 4800

2 = 9600

3 = 19200

4 = 38400

P92 RS232 mode [0, 3]

0 = RS232 protocol according to DIN66019

1 = Printer mode. To transmit actual value periodically to a printer at a time interval set in parameter **P93**.

2 = Printer mode. To transmit actual value to a printer when pushing **E** button.

3 = Printer mode. To transmit actual value to a printer when activating Input CON2/pin 5.

P93 Transmission time interval [0.01, 650.00]

Enter the time interval for periodic actual value transmission in sec. (**P92** must be =1).

Default value: **1.00**

Menu 3: Axis 1

P00 Actual value for RS232 [-99999, 999999]

This parameter shows the actual value for serial transmission via RS232 Interface if parameter

P92(menu 2) = 0.

P02 Datum value / Preset [-99999, 999999]

Display can be set to datum value (or preset) by activating SET input or pushing **↑** key.

Default value: **50.0**

P05 Display value per distance moved [1, 10000]

Enter the value to be displayed when the unit receives the number of pulses per distance moved in parameter P06. Note this value is entered without decimal.

Default value: **100**

P06 Nr. of pulses per distance moved [1, 65000]

Enter the number of pulses per distance. This same distance unit is used to determine the Display value per distance moved.

Default value: **100**

Example:

A ball screw moves 12.3mm per revolution. The system uses a rotary encoder with 200 PPR (pulses per revolution).

In this case:

P05 should be set to 123 (value without decimals)

P06 is 200

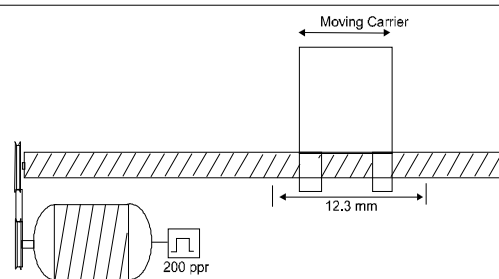

P22 Measuring system selection [0, 1]

0 = encoder signals: A, B e 0

1 = encoder signals: A, /A, B, /B, 0, /0

P25 Encoder edge counting mode [1, 4]

1 = x 1 (1 edge counting mode)

2 = x 2 (2 edge counting mode)

4 = x 4 (4 edge counting mode)

For linear magnetic measurement systems set 4.

Example:

A magnetic sensor SME5 with 0,01mm resolution has to be displayed. The measurement length is 100,00 mm. The sensor outputs 10000 pulses (after quad.).

P05 is 10000 (100,00mm without decimals)

P06 is 10000 (pulses)

P252 is 4 (signal quadrature)

P26 Counting direction [0, 1]

Sets counting direction of display.

0 = standard counting direction

1 = inverted counting direction

P40 Decimal point [1, 4]

Modification of decimal point position. This setting has no influence on other parameters.

0 = 000000

1 = 00000.0

....

4 = 00.0000

P41 Led intensity [0, 15]

Set intensity of 7 segment LEDs.

0 = minimum intensity

...

15 = maximum intensity

P60 Encoder Index function [0, 2]

Function not used.

P70 Offset [0, 65000]

Value entered here will be subtracted from actual value by activating Offset function (Input 4).

By deactivating Offset input, Offset value will be added to actual value.

Default value: **10.0**

P71 Saw blade offset [-10000, +10000]

Here a value can be stored which is subtracted from the display value when the Set or Reset function is activated in incremental mode.

Default value: **0**

P80 Relay output configuration [0, 1]

0 = static relay output

1 = with relay output dwell time

P81 Output 1 [-99999, 999999]

Output 1 will be activated when actual value is more than Output 1 value.

Default value: **10.0**

P82 Output 2 [-99999, 999999]

Output 2 will be activated when actual value is more than Output 2 value.

Default value: **20.0**

P85 Relay 1 dwell time [0, 2.50]

Enter relay dwell time between 0 and 2.50 seconds. P80 must be 1.

Default value: **0**

P86 Relay 2 dwell time [0, 2.50]

Enter relay dwell time between 0 and 2.50 seconds. P80 must be 1.

Default value: **0**

P89 Output logic [0, 3]

Enter output logic of Output 1 and Output 2.

0 = Output 1 activated when Actual value > P81

Output 2 activated when Actual value > P82

1 = Output 1 activated when Actual value < P81

Output 2 activated when Actual value > P82

2 = Output 1 activated when Actual value > P81

Output 2 activated when Actual value < P82

3 = Output 1 activated when Actual value < P81

Output 2 activated when Actual value < P82

Menu 4: Axis 2

P00 Actual value for RS232 [-99999, 999999]

This parameter shows the actual value for serial transmission via RS232 Interface if parameter **P92**(menu 2) = 0.

P02 Datum value / Preset [-99999, 999999]

Display can be set to datum value (or preset) by activating SET input or pushing **↑** key.

Default value: **50.0**

P05 Display value per distance moved [1, 10000]

Enter the value to be displayed when the unit receives the number of pulses per distance moved in parameter P06. Note this value is entered without decimal.

Default value: **100**

P06 Nr. of pulses per distance moved [1, 65000]

Enter the number of pulses per distance. This same distance unit is used to determine the Display value per distance moved.

Default value: **100**

Example:

A ball screw moves 12.3mm per revolution. The system uses a rotary encoder with 200 PPR (pulses per revolution).

In this case:

P05 should be set to 123 (value without decimals)

P06 is 200

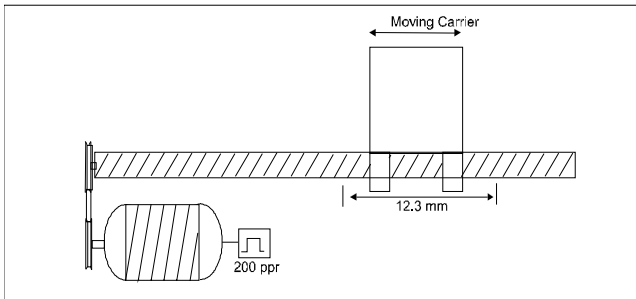

P22 Measuring system selection [0, 1]

0 = encoder signals: A, B e 0

1 = encoder signals: A, /A, B, /B, 0, /0

P25 Encoder edge counting mode [1, 4]

1 = x 1 (1 edge counting mode)

2 = x 2 (2 edge counting mode)

4 = x 4 (4 edge counting mode)

For linear magnetic measurement systems set 4.

Example:

A magnetic sensor SME5 with 0,01mm resolution has to be displayed. The measurement length is 100,00 mm. The sensor outputs 10000 pulses (after quad.).

P05 is 10000 (100,00mm without decimals)

P06 is 10000 (pulses)

P252 is 4 (signal quadrature)

P26 Counting direction [0, 1]

Sets counting direction of display.

0 = standard counting direction

1 = inverted counting direction

P40 Decimal point [1, 4]

Modification of decimal point position. This setting has no influence on other parameters.

0 = 000000

1 = 00000.0

....

4 = 00.0000

P41 Led intensity [0, 15]

Set intensity of 7 segment LEDs.

0 = minimum intensity

...

15 = maximum intensity

P60 Encoder Index function [0, 2]

Function not used.

P70 Offset [0, 65000]

Value entered here will be subtracted from actual value by activating Offset function (Input 4).

By deactivating Offset input, Offset value will be added to actual value.

Default value: **10.0**

P71 Saw blade offset [-10000, +10000]

Here a value can be stored which is subtracted from the display value when the Set or Reset function is activated in incremental mode.

Default value: **0**

8 - RS232 interface

8.1 PC connection

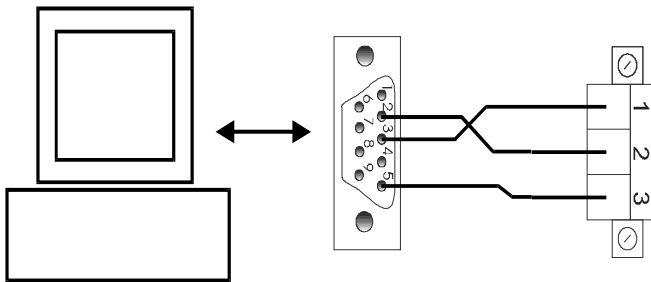

Use 9 pin DSub connector and connect with CON4 of the MC221 readout.

Pin	Function
1	RxD Reception data
2	TxD Transmission data
3	GND Ground

Make sure that RxD on PC side is connected with TxD on MC221 side and TxD / PC is connected with RxD / MC221.

8.2 Technical data

Function	Data
Baud rate	2400,4800,9600,19200,38400
Data bits	7 bit ASCII
Parity bit	1 (even)
Stop bit	1
Flow control	No

8.3 Communication protocol

The RS232 protocol is according to DIN 66019, ISO 1765, ANSI X3.28.

The PC is the master and the MC221 is the slave with individual serial address to be entered in Parameter **P90**.

There are 3 ways of communication:

- Send
- Receive
- Broadcast

8.3.1 Protocol structure

Field	Value	Function
EOT	04 H	End Of Transmit
AD1	ascii	Unit address, MSByte
AD2	ascii	Unit address, LSByte
STX	02 H	Start of TeXt
C1,C2	ascii	Level code = 20 : Level 1 ... 23: Level 4
C3,C4	ascii	Parameter code = 00...99
DATA	n byte ascii	Process data
ETX	03 H	End of TeXt
BCC	ascii	Block Check Character
ENQ	05 H	ENQuiry
NAK	15 H	Not Acknowledge
ACK	06 H	Acknowledge

NOTE:

- **BCC** (block-check-character) is a character used for check the correct transmission. It is generated by XOR-ing characters C1, C2, C3, C4, DATA and ETX (including). If BCC < 20 Hex, BCC must be added up with 20 Hex, this avoids BCC to have values in the range of control character values.
- **DATA** field can contain any number of numerical characters, a sign and can be filled up with zeros. All DATA are sent in ASCII Code.

8.3.2 Send data from Master to Slave

PC → MC221

EOT	AD1	AD2	STX	C1	C2	C3	C4
-----	-----	-----	-----	----	----	----	----

DATA	ETX	BCC
------	-----	-----

When transmission is correct slave replies with ACK in any other cases with NAK.

MC221 → PC

ACK	or	NAK
-----	----	-----

All parameters sent to the slave are stored in a data buffer. Parameters have to be activated by the "activate parameter" command (see chap. 8.3.4).

Example:

Sets the parameter P02 = 100 (unit address = 11).
PC → MC221

	EOT	AD1	AD2	STX	C1	C2	C3	C4
ascii		1	1		2	2	0	2
Hex	04	31	31	02	32	32	30	32

	DATA			ETX	BCC
ascii	1	0	0		
Hex	31	30	30	03	30

MC221 → PC

	ACK
ascii	
Hex	06

8.3.3 Receive data from slave

PC → MC221

EOT	AD1	AD2	STX	C1	C2	C3	C4	ENQ
-----	-----	-----	-----	----	----	----	----	-----

The correct reception of the string is acknowledged with the following message:

MC221 → PC

STX	C1	C2	C3	C4	DATA	ETX	BCC
-----	----	----	----	----	------	-----	-----

The reception of a incorrect string is followed by a negative acknowledgment like:

MC221 → PC

STX	C1	C2	C3	C4	EOT
-----	----	----	----	----	-----

in any other cases with "NAK":

MC221 → PC

NAK

Example:

Read actual value (unit address = 11).

PC → MC221

	EOT	AD1	AD2	STX	C1	C2	C3	C4	ENQ
ascii		1	1		2	2	0	0	
Hex	04	31	31	02	32	32	30	30	05

If actual value = 12 acknowledge message will be:

MC221 → PC

	STX	C1	C2	C3	C4	DATA	ETX	BCC
ascii		2	2	0	0	1	2	
Hex	02	32	32	30	30	31	32	03

8.3.4 Serial commands

All commands are sent with parameter P52 (C1, C2, C3, C4 fields = 2152). See "Send data from Master to Slave" (chap. 8.3.2)

The following commands are available:

- Activate data: DATA=137
- Save data to EEPROM: DATA=138
- Set datum: DATA=139

Example:

Send "Activate data" (unit address = 11).

PC → MC221

	EOT	AD1	AD2	STX	C1	C2	C3	C4
ascii		1	1		2	1	5	2
Hex	04	31	31	02	32	31	35	32

	DATA			ETX	BCC
ascii	1	3	7		
Hex	31	33	37	03	32

MC221 → PC

	ACK
ascii	
Hex	06

8.3.5 Printer mode

When a printer is connected to the MC221 the following data string will be transmitted:

MC221 → printer

AD1	AD2	DATA	LF	CR
xx	xx	xx	0A Hex	0D Hex

The MC221 is sending its serial address followed by the actual value and Line Feed (LF) and Carriage Return (CR).

9 - Dimensional drawing and cut-out

Check details on product catalogue.

Provide a 92 x 92 mm² (w x h) cut-out.

Rev	SW	Man. Vers.	Description
0		1.0	1st issue



Lika Electronic

Via S. Lorenzo, 25 - 36010 Carrè (VI) - Italy

Tel. +39 0445 382814

Fax +39 0445 382897

Italy: eMail info@lika.it - www.lika.it

World: eMail info@lika.biz - www.lika.biz